



GMD Process Maps

v 5.06

Last Updated: March 28, 2022

- GMD-1 Review, Obligation, Approval and Award Offer
- GMD-1B Obligation – Grants Online/CBS/ASAP
- GMD-2 Administrative Amendment – Date Changes
- GMD-3 Change in High Risk Indicator
- GMD-4 Closeout Workflow

For a step by step tutorial of this process map, please reference the following:

- Grants Specialist and Grants Officer Training Package
 - Closeout Processing



Federal Employee (including GMD)



Grants Online Document

Grants Online Hard Stop Codes

- HS = "Vendor and Funding"
- HSP = "Vendor and Funding – POST"
- HSFP = "Funding Only - POST"
- HSV = "Vendor Only"
- HSF = "Funding Only"



Grantee

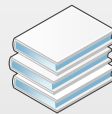

Multiple
Grants Online
Documents



"Interface" User



CBS
Interface
Task

- VV = Vendor Transaction – Validate
- VC = Vendor Transaction - Create
- P = Procurement Request Transaction
- O = Obligation Transaction
- C = Closeout Transaction
- SN = SF-270 – Non-ASAP Transaction
- SA = SF-270 – ASAP Transaction



Reviewers



Process Step



Notification



Important Note

GMD Review, Obligation, Approval and Award Offer (GMD-1)

March 28, 2022

Version 5.06

"Review Award File" Task is placed into Grants Specialist's Inbox when FPO forwards Award File. A task also goes to Public Affairs (based on the Bureau Threshold*) to attach Press Release. (Canceled if no action taken as of GO approval -Step 10.)

*Bureau Threshold:
 (IF EDA, all Grants) / (IF Census, no Grants)
 OR
 (IF Other Bureau > \$500,000 Only)

Nightly Upload to CBS DW for ARRA
 File generation for FAADS/USASpending

Award Files cannot be signed by Grants Officer if there is a pending amendment.

AUTOMATED TASK

Nightly Upload to MARS

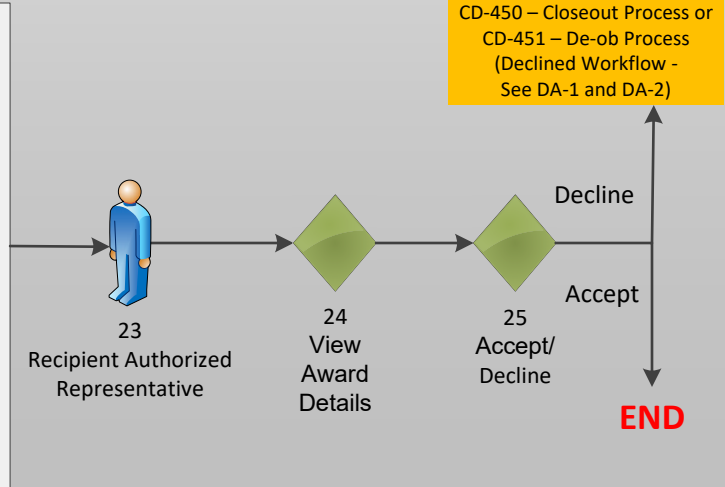
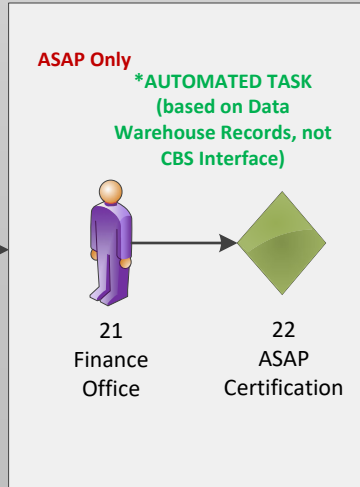
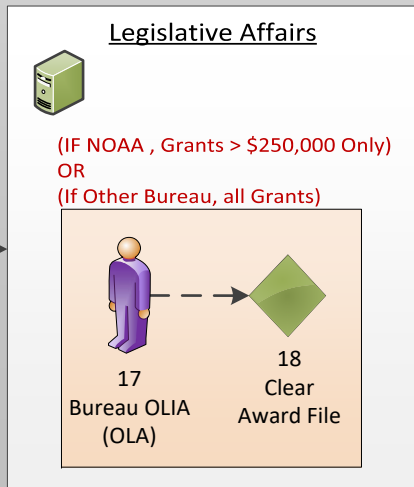
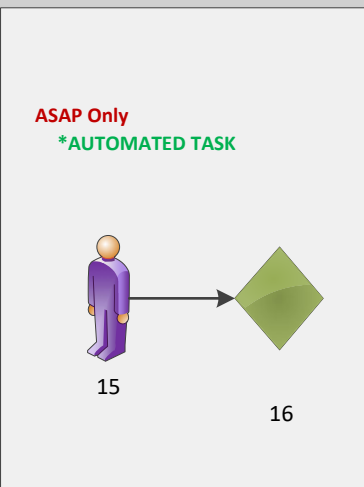
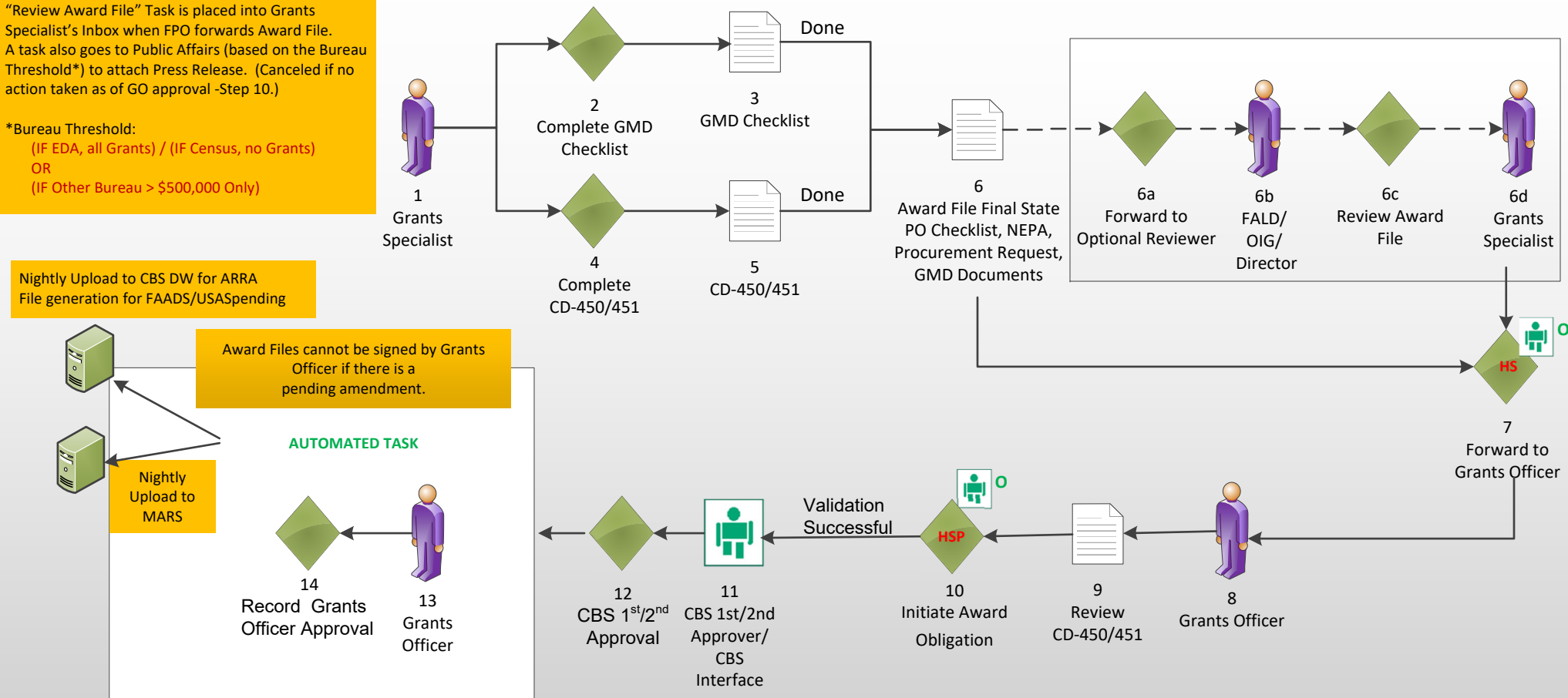

This Process Map corresponds to steps 8-23 of the GMD-1 Process Map and outlines the steps that need to be taken in Grants Online, CBS and ASAP.

GOL / CBS / ASAP Obligation Process Flow

Color Chart

- GMD Step
- Finance Office Step
- Automated/Interface

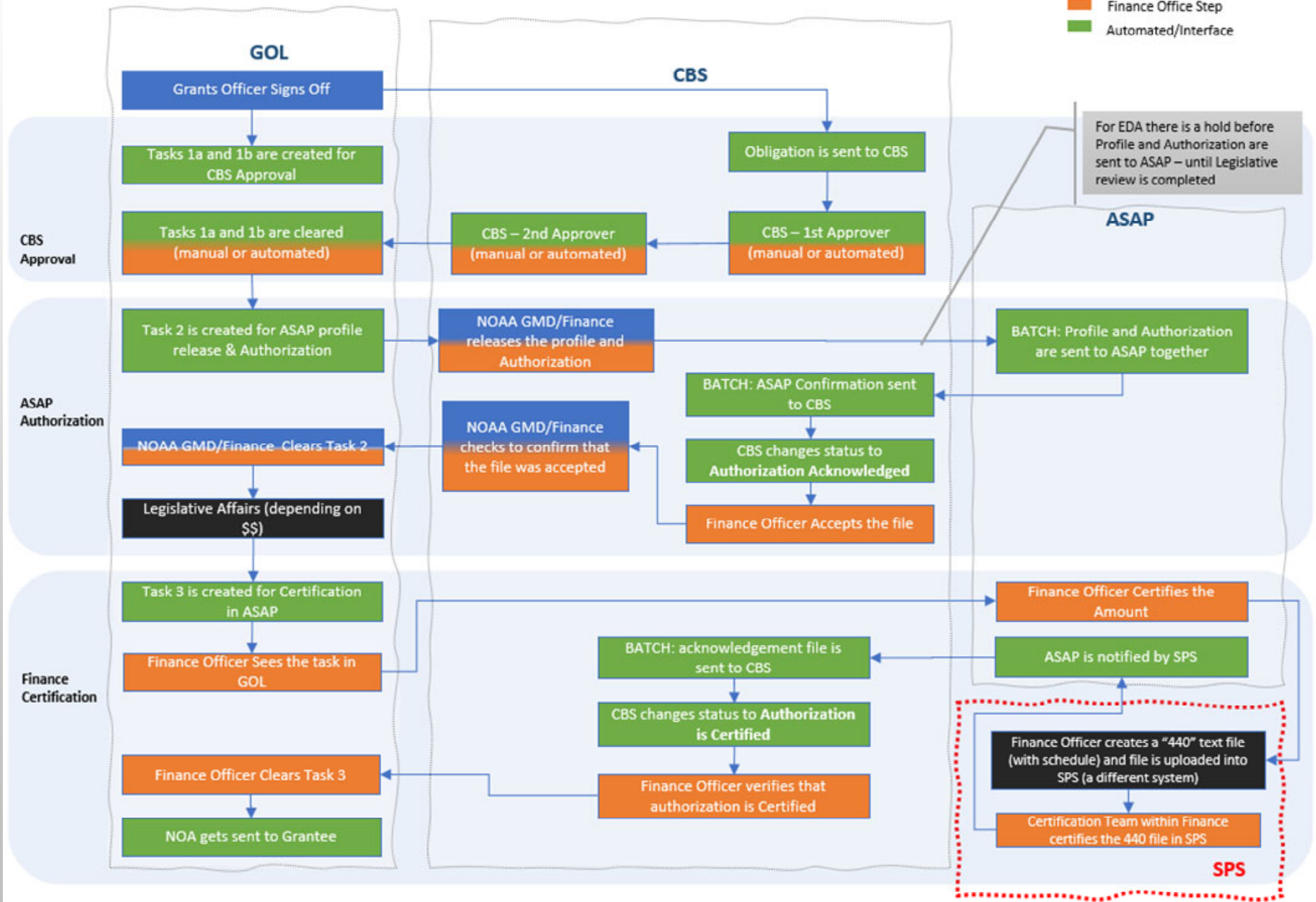

Administrative Amendment – Date Changes (GMD-2)

March 28, 2022

Non-Funded Amendment

Version 5.06

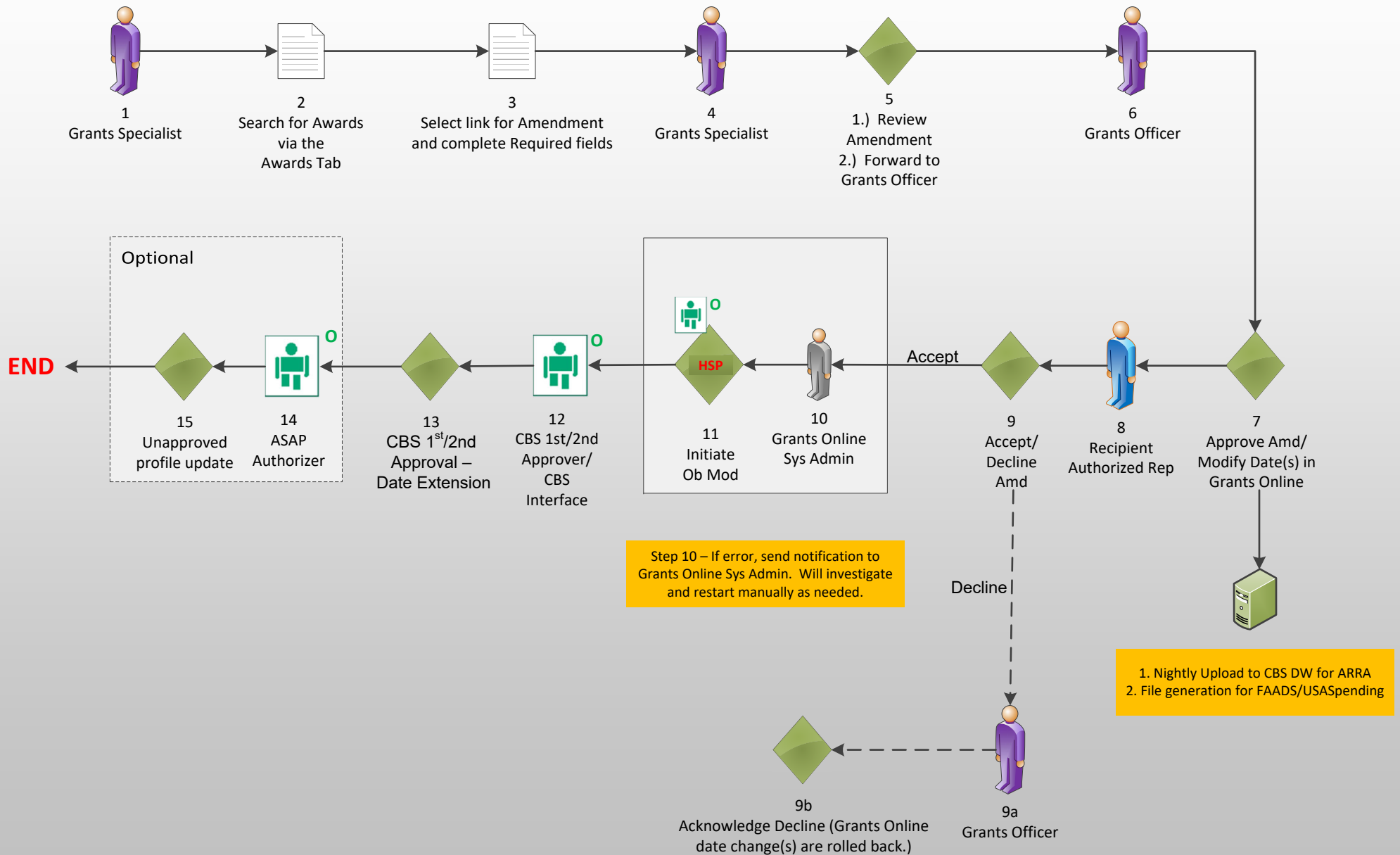

Change in High Risk Indicator (GMD-3)

(NOAA ASAP Recipients Only)

March 28, 2022

Version 5.06

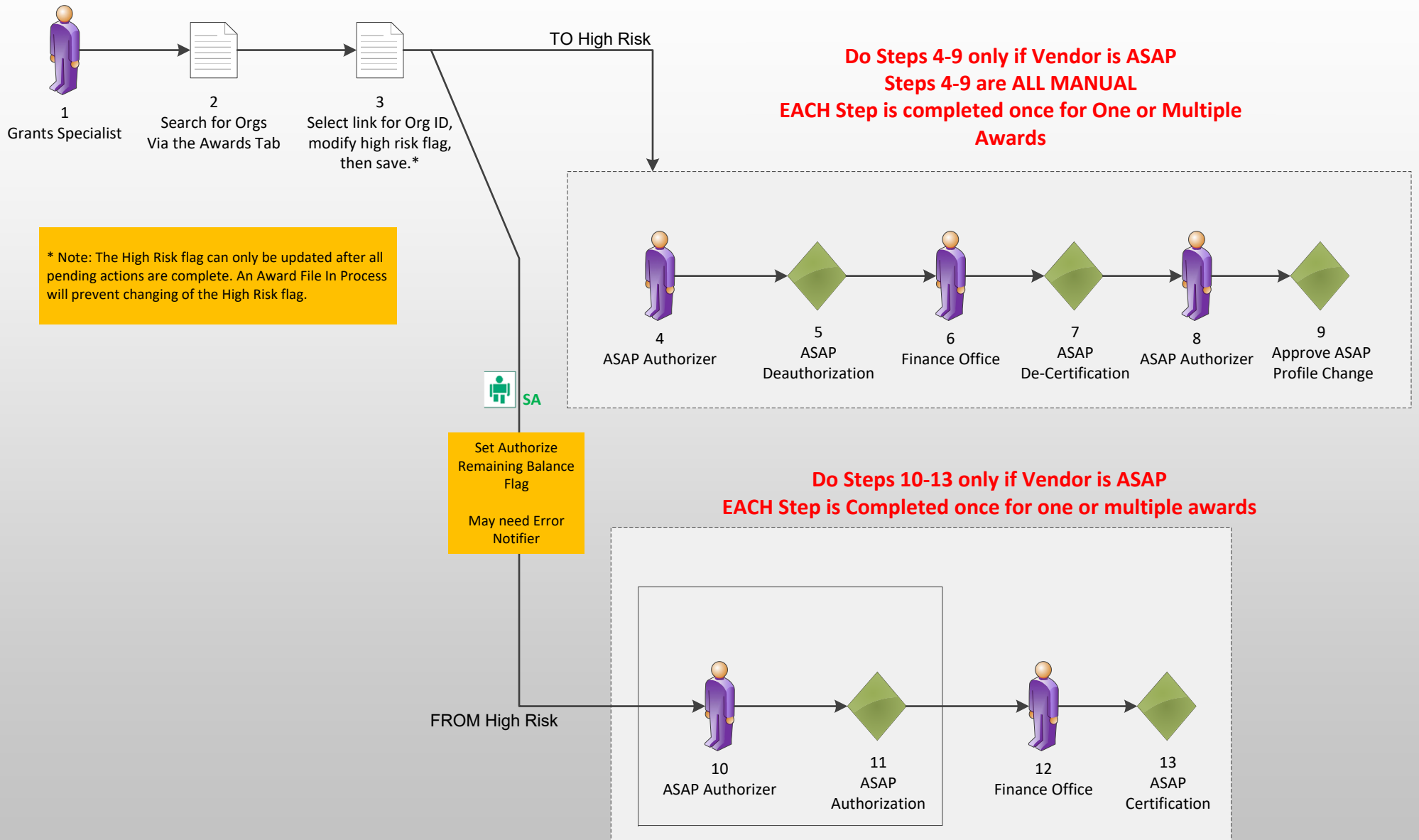

Closeout Workflow (GMD-4)

March 28, 2022

Version 5.06

